

L-handle Non Locking Nose Indexing Pin

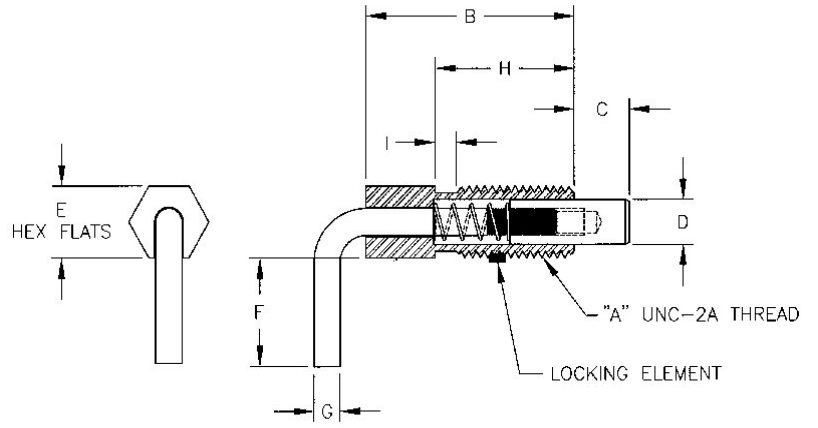

料号 Part Number		牙型 Thread	牙长 Thread Length	Body Length	Nose Length	Nose Dia	Hex Size	Handle Length	Handle Dia	Thread Relief	作用力 End Pressure (lbs.)	
环保铁 Steel	不锈钢 Stainless	A	H	B	C	D	E	F	G	I	起始 Start	结束 Final
SLNP-01	SSLNP-01	1/4-20	0.50	0.75	0.20	0.16	1/4	0.40	0.09	-	0.12	0.50
SLNP-02	SSLNP-02	1/4-20	0.80	1.25	0.38	0.16	1/4	0.50	0.09	-	0.50	2.50
SLNP-03	SSLNP-03	3/8-16	0.75	1.13	0.30	0.25	3/8	0.56	0.14	0.13	0.25	1.25
SLNP-04	SSLNP-04	3/8-16	1.31	2.00	0.56	0.25	3/8	0.75	0.14	0.13	0.75	3.75
SLNP-05	SSLNP-05	1/2-13	1.00	1.50	0.40	0.31	1/2	0.75	0.19	0.13	0.50	2.00
SLNP-06	SSLNP-06	1/2-13	1.25	2.11	0.75	0.31	1/2	1.00	0.19	0.13	1.00	5.00
SLNP-07	SSLNP-07	5/8-11	1.25	1.88	0.50	0.38	5/8	0.88	0.19	0.13	0.75	2.50
SLNP-08	SSLNP-08	5/8-11	2.00	3.05	1.00	0.38	5/8	1.00	0.19	0.13	1.00	5.00

料号 P/N#: SLNP-01-LE,

材料 Material: 不锈钢 Stainless Steel,

牙型 Thread: 1/4-20,

有锁紧成分 locking element

有锁紧成分 Locking Element: -LE

无锁紧成分 Non Locking Element: -NLE

T Handle Locking Nose Plungers

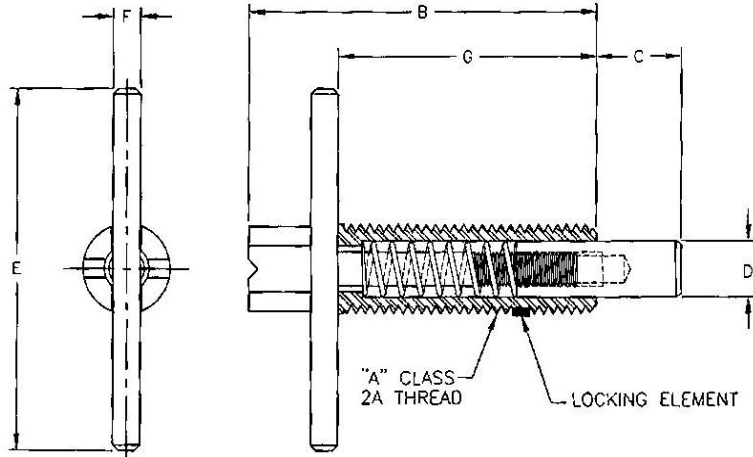

料号 Part Number		作用力		Thread A	B	C	D	E	F	G
环保铁 Steel	不锈钢 Stainless	起始 Start	结束 Final							
STLP-14	SSTLP-14	1	2.5	1/4-20	1.14	0.250	0.155	1.13	0.13	0.8
STLP-38	SSTLP-38	2	4	3/8-16	1.68	0.375	0.233	1.50	0.13	1.2
STLP-12	SSTLP-12	2	5	1/2-13	2.00	0.500	0.312	2.00	0.16	1.4
STLP-58	SSTLP-58	2.5	5	5/8-11	2.38	0.625	0.375	2.50	0.19	1.7

料号 P/N#: SSTLP-14-LE,

材料 Material: 不锈钢 Stainless Steel,

牙型 Thread: 1/4-20,

有锁紧成分 locking element

有锁紧成分 Locking Element: -LE

无锁紧成分 Non Locking Element: -NLE